

Art. 1281

FILTRO DEPURAZIONE ACQUA FLANGIATO - BRONZO
FLANGED WATER STRAINER - BRONZE

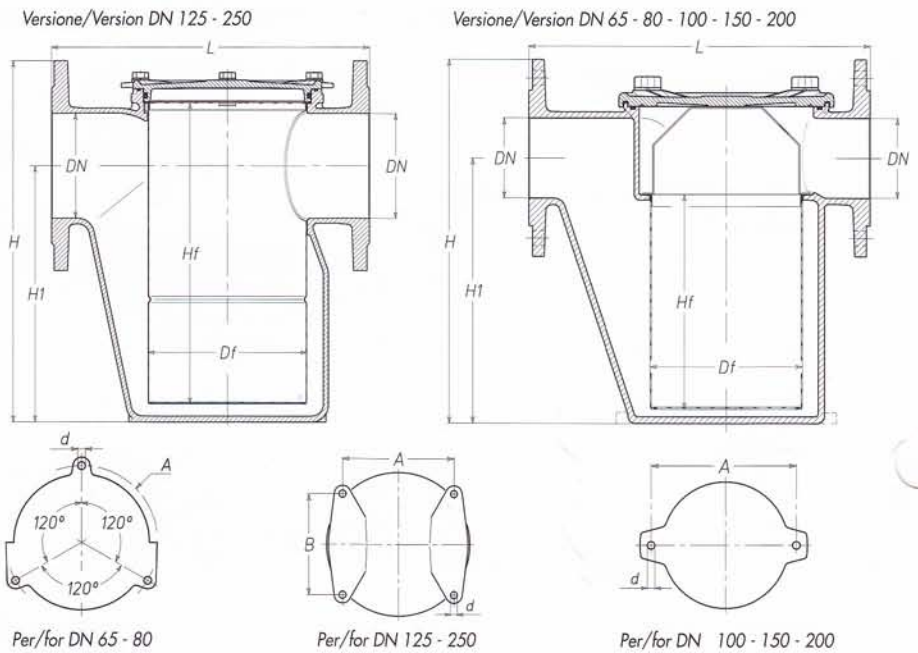

- Corpo in bronzo
- Elemento filtrante in acciaio inox AISI 316L
- Coperchio in bronzo
- Guarnizioni in neoprene

- Bronze casing
- AISI 316L stainless steel inside filter
- Bronze cover
- Neoprene o-ring

Weight (gr)	14500	21000	27000	39000	65000	96000	138500				
d	6.5	8.5	12.5	10.5	12.5	12.5	12.5				
A	180	225	244	188	320	410	320				
B	-	-	-	170	-	-	280				
H	296	306	415	431	483	600	685				
H1	216	211	310	306	350	440	485				
L	278	330	355	380	506	600	600				
Hf	175	151	260	360	288	350	580				
Df	124	165	165	190	220	248	308				
DN	25	32	40	50	65	80	100	125	150	200	250

PORTATE DI ACQUA ATTRAVERSO
 IL FILTRO PULITO - lt/h
 FLOW-RATE CAPACITY THROUGH
 THE CLEAN FILTER - lt/h

DN	0.1 bar	1 bar
65	36990	116980
80	56040	177200
100	87500	276700
125	136810	432630
150	196900	622700
200	350000	1107000
250	564500	1785400

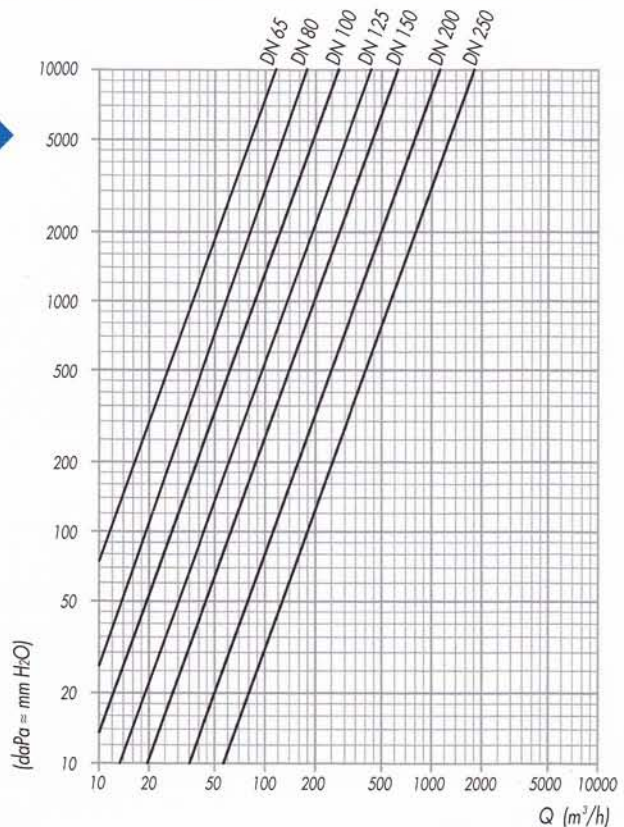

OMOLOGAZIONE / CERTIFICATE
RINA MAC

