

The MJP Ultrajet range excels where high bollard pull and exceptional acceleration is a specified craft requirement and boat speed must not be sacrificed to achieve this.

## MJP Ultrajet 410

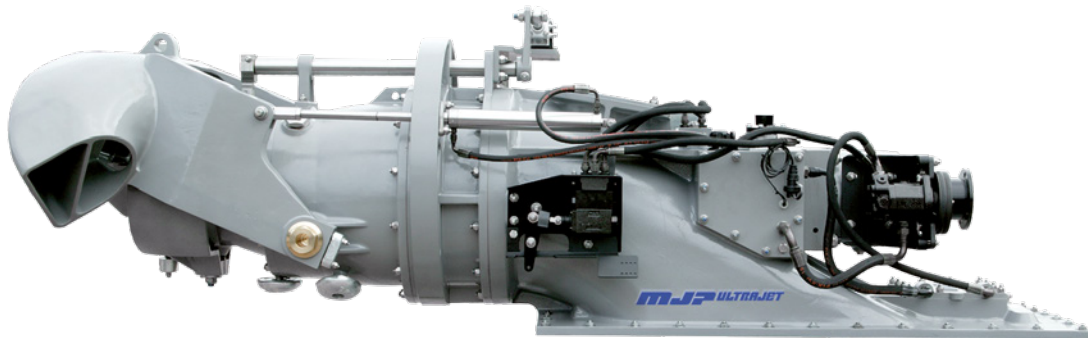

Lloyds ISO9001 approved

### Features & Benefits

- Compact design with jet-mounted control system
- High propulsive efficiency
- Superior manoeuvrability. Ability to accelerate quickly, reverse, stop, rotate, hold station and move sideways/easier docking
- Excellent resistance to cavitation in displacement craft - superior thrust at low boat speeds compared to other propulsion systems
- Lower vibration and noise levels than other propulsion methods
- Integral hydraulic reservoir and oil cooler
- Manufactured to highest military and marine quality standards
- MJP Ultrajet Joystick Control Systems mean complex craft manoeuvres are easier for the operator. Simple to fit - supplied as plug and play
- Inboard hydraulic cylinders for reverse deflector operation
- MJP-developed electrohydraulic reversing controls
- Integral jet-driven hydraulic pump
- Higher mid-range thrust for improved cruising speed and fuel economy
- Minimal service costs over life of system

### Description

MJP Ultrajet 410 with a 410mm (16.1") diameter impeller provides higher thrust per horsepower when matched to modern engines in the 336–746 kW range. The MJP Ultrajet 410 is the latest in the range of high performance MJP Ultrajet drives developed for commercial, pleasure and military craft.

Single stage design utilising four or five blade impellers to match the specified engine power at a range of input speeds.

The MJP Ultrajet 410 is derived from the Ultra and Dowty jet drive range used in military and commercial applications. The hydrodynamically designed MJP Ultrajet 410 incorporates an efficient and robust axial flow pump, reverse and steering controls, and is the culmination of over 45 years of research, development and practical experience.

### Planing Craft

Maximum input power 746 kW (1000 bhp)

Single jet up to 14 tonnes (30,856 lb.)

Twin jets up to 32 tonnes (70,528 lb.)

Triple jets up to 50 tonnes (110,200 lb.)

### Displacement Craft

Maximum input power 336 kW (450 bhp)

Single jet up to 28 tonnes (61,712 lb.)

Twin jets up to 60 tonnes (132,240 lb.)

Triple jets up to 90 tonnes (198,360 lb.)

Note: The displacement figures can often be exceeded on good hull shapes.

## MJP Ultrajet 410

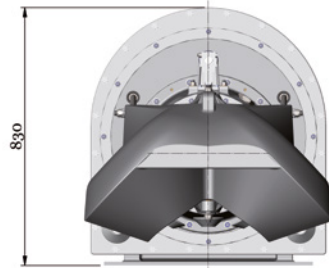
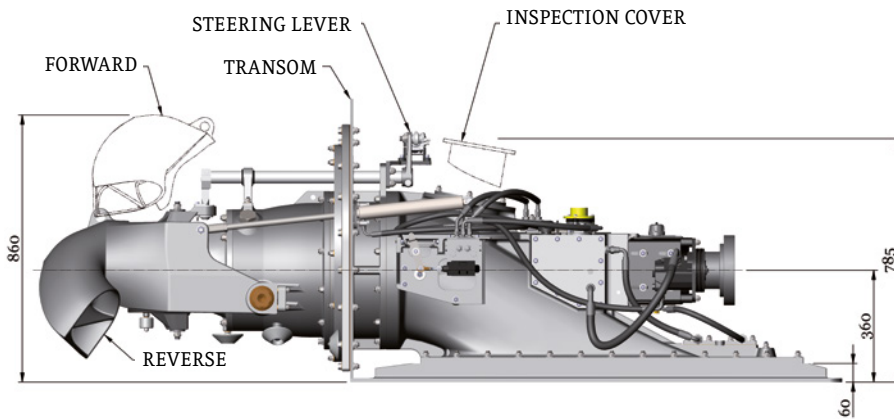

OUTBOARD VIEW OF MJP ULTRAJET UNIT

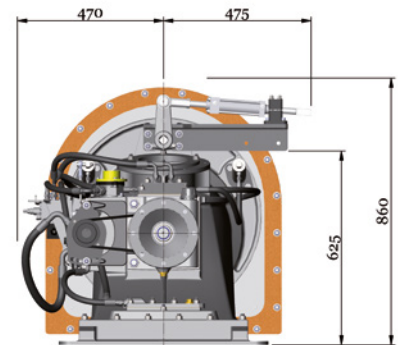
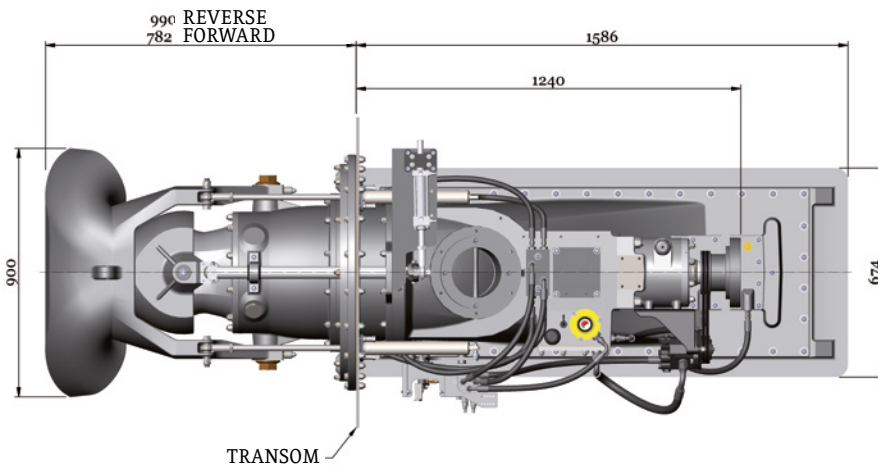

INBOARD VIEW OF MJP ULTRAJET UNIT

### Typical Specifications:

1. Impellers are available to match most diesel engine and transmission combinations for optimum thrust performance.
2. DIN, SAE or other drive flange options are available.
3. Unit weight 440 kg (970 lb.) dry or 547 kg (1,206 lb.) including entrained water. (For guideline only - if a detailed weight analysis is required please contact our Technical Department).
4. Consult Marine Jet Power Technical Department for vessel and performance analysis.

We have a policy of continuous improvement in design. Specifications may, therefore, be changed without notice. When considering applications for this equipment it is recommended that our Technical Sales Department is consulted.