

The MJP Ultrajet range excels where high bollard pull and exceptional acceleration is a specified craft requirement and boat speed must not be sacrificed to achieve this.

MJP Ultrajet 452

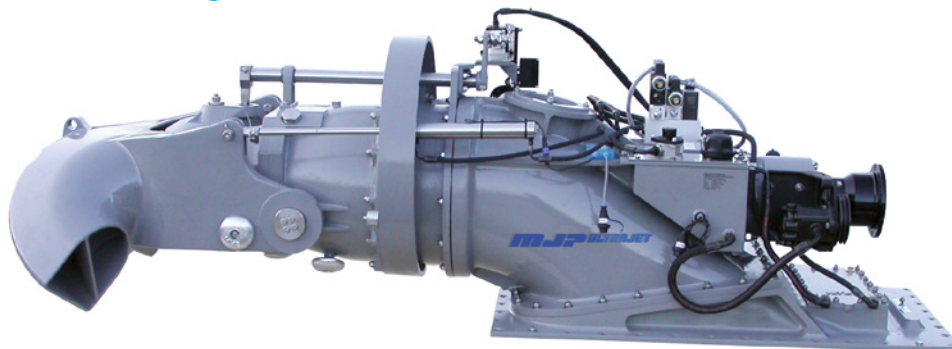

Lloyds ISO9001 approved

Features & Benefits

- Low profile for lower decks
- Hydrodynamic intake housing with integral oil cooler
- Higher inspection cover to prevent overflow
- Higher mid-range thrust for improved cruising speed and economy
- Less static hull immersion required for initial priming
- Wide range of MJP-developed hydromechanical and electrohydraulic reversing controls
- High propulsive efficiency
- Standard rubber impeller shaft bearing or optional composite bearing if dry running is required
- Superior manoeuvrability. Ability to accelerate quickly, reverse, stop, rotate, hold station and move sideways for ease of docking.
- Excellent resistance to cavitation in displacement craft – high thrust at low speed
- Lower vibration and noise levels than other propulsion methods

Description

MJP Ultrajet 452 is derived from the Ultra (formerly Dowty) jet drive range, which has been used extensively in military and commercial applications for over 40 years. The MJP Ultrajet 452 is a single stage axial flow design incorporating an impeller with a diameter of 450mm (17.7 inches), which develops higher thrust per horsepower at boat speeds between 0–20 knots than any equivalent sized waterjet on the market. The hydraulic reverse control system has been totally integrated onto the waterjet, simplifying the installation for the boat builder and allowing the complete reverse control system to be factory tested before despatch.

Planing Craft

Maximum input power 900 kW (1200 bhp)

Twin jets up to 35 tonnes (77,140 lb.)

Triple jets up to 55 tonnes (121,220 lb.)

Quad jets up to 70 tonnes (154,280 lb.)

Semi-Displacement Craft

Maximum input power 761 kW (1020 bhp)

Twin jets up to 52 tonnes (114,608 lb.)

Triple jets up to 80 tonnes (176,320 lb.)

Quad jets up to 112 tonnes (246,848 lb.)

Displacement Craft

Maximum input power 410 kW (550 bhp)

Twin jets up to 65 tonnes (143,260 lb.)

Triple jets up to 100 tonnes (220,400 lb.)

Quad jets up to 140 tonnes (308,560 lb.)

Note: The displacement figures below can often be exceeded on good hull shapes.

MJP Ultrajet 452

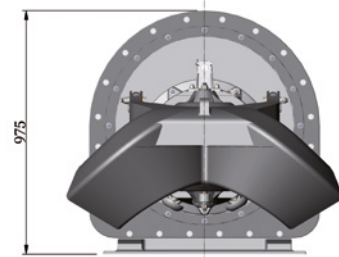
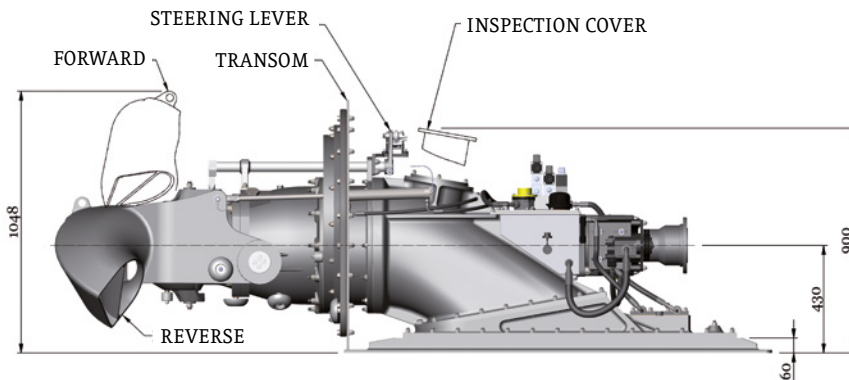

OUTBOARD VIEW OF MJP ULTRAJET UNIT

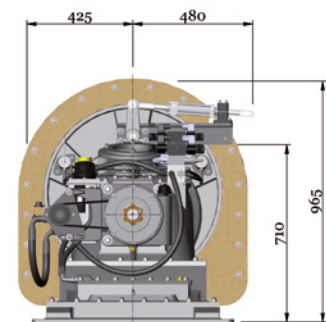
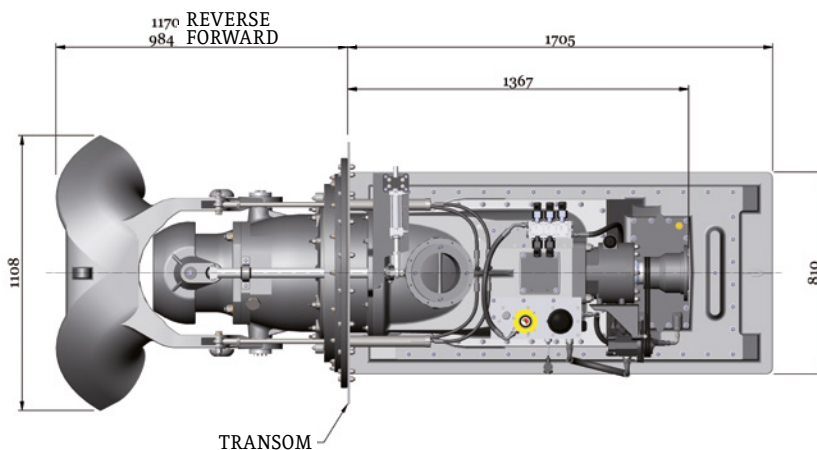

INBOARD VIEW OF MJP ULTRAJET UNIT

Typical Specifications:

1. Impellers are available to match most diesel engine and transmission combinations for optimum thrust performance.
2. DIN, SAE or other drive flange options can be supplied.
3. Unit weight 643 kg (1,418 lb.) dry (including hydraulic system and controls) or 763 kg (1,683 lb.) including entrained water.
4. Consult Marine Jet Power Technical Department for vessel and performance analysis.

We have a policy of continuous improvement in design. Specifications may, therefore, be changed without notice. When considering applications for this equipment it is recommended that our Technical Sales Department is consulted.