

The MJP Ultrajet range excels where high bollard pull and exceptional acceleration is a specified craft requirement and boat speed must not be sacrificed to achieve this.

MJP Ultrajet 525

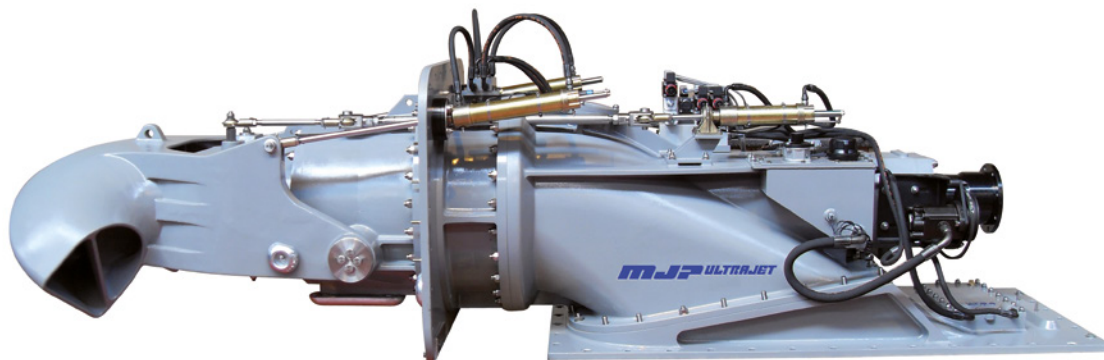

Lloyds ISO9001 approved

Features & Benefits

- Light weight and compact design with a variety of jet mounted hydraulic control systems to minimise installation time
- High propulsive efficiency and mid-range thrust for improved cruising speed and economy
- Superior manoeuvrability. Ability to accelerate quickly, reverse, stop, rotate, hold station and move sideways/ easier docking
- Excellent resistance to cavitation in displacement craft – superior thrust at low boat speeds compared to other propulsion systems
- Lower vibration and noise levels than other propulsion methods
- Ultrajet Joystick Control Systems mean complex craft manoeuvres are easier for the operator. Simple to fit – supplied as plug and play
- Wide range of Marine Jet Power developed electro-hydraulic control systems available across the complete MJP Ultrajet range
- Standard rubber impeller shaft bearing or optional composite bearing if dry running is required or operation in aggressive water conditions

Description

The MJP Ultrajet 525 with a 525mm (20.7”) diameter impeller provides higher thrust per horsepower and can be used with engines up to 1100 kW.

The hydrodynamically designed MJP Ultrajet 525 incorporates an efficient and robust axial flow pump utilising a range of five bladed impellers to match various engine and gearbox combinations and is the culmination of over 45 years of research, development and practical experience. MJP Ultrajet drives have been developed for commercial, pleasure and military craft.

The MJP Ultrajet 525 can be supplied with a full range of electro-hydraulic steering and reverse control systems including multi-station joystick control systems if required.

Planing Craft

Maximum input power 1100 kW (1475 bhp)

Twin jets up to 45 tonnes (99,180 lb.)

Triple jets up to 72 tonnes (158,688 lb.)

Quad jets up to 100 tonnes (220,400 lb.)

Semi-Displacement Craft

Maximum input power 935 kW (1254 bhp)

Twin jets up to 76 tonnes (167,504 lb.)

Triple jets up to 116 tonnes (255,664 lb.)

Quad jets up to 160 tonnes (352,640 lb.)

Displacement Craft

Maximum input power 500 kW (670 bhp)

Twin jets up to 95 tonnes (209,380 lb.)

Triple jets up to 145 tonnes (319,580 lb.)

Quad jets up to 200 tonnes (440,800 lb.)

Note: the displacement figures above can often be exceeded on good hull shapes.

MJP Ultrajet 525

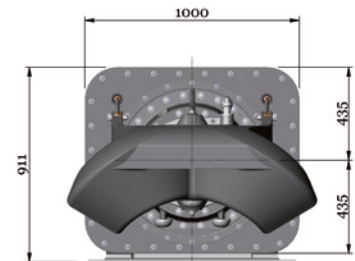
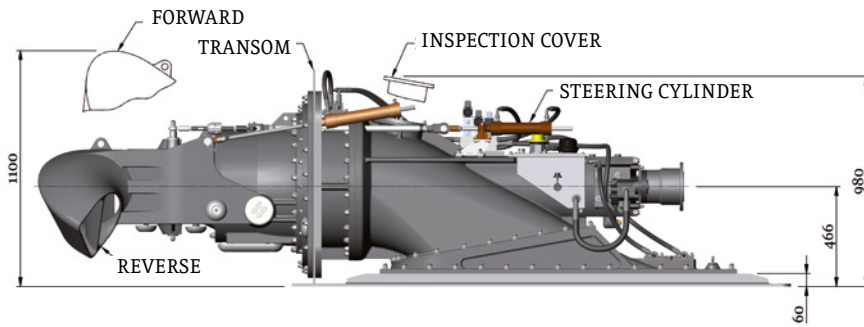

OUTBOARD VIEW OF MJP ULTRAJET UNIT

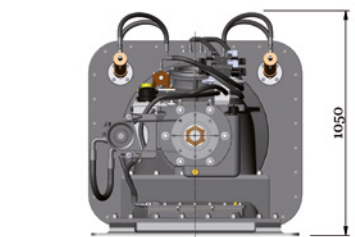
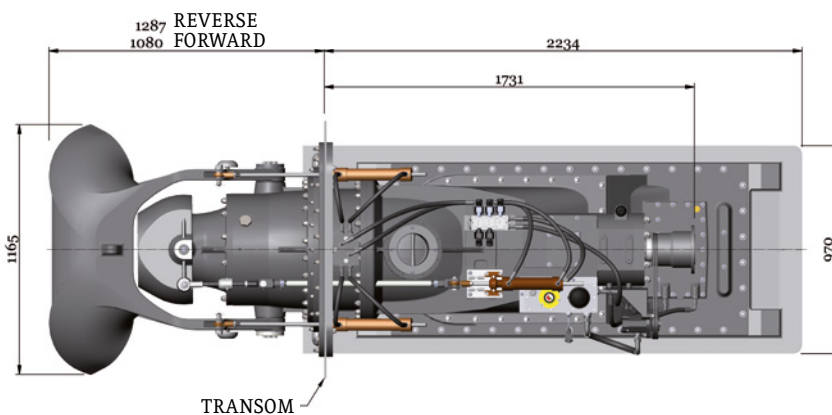

INBOARD VIEW OF MJP ULTRAJET UNIT

Typical Specifications:

1. Impellers are available to match most diesel engine and transmission combinations for optimum thrust performance.
2. DIN, SAE or other drive flange options are available.
3. Unit weight 1,150 kg (2,535 lb.) dry (including hydraulic system and controls) or 1,328 kg (2,927 lb.) including entrained water.
4. Consult Marine Jet Power Technical Department for vessel and performance analysis.

We have a policy of continuous improvement in design. Specifications may, therefore, be changed without notice. When considering applications for this equipment it is recommended that our Technical Sales Department is consulted.