

Marine Turbine Series

Marine Turbine Series

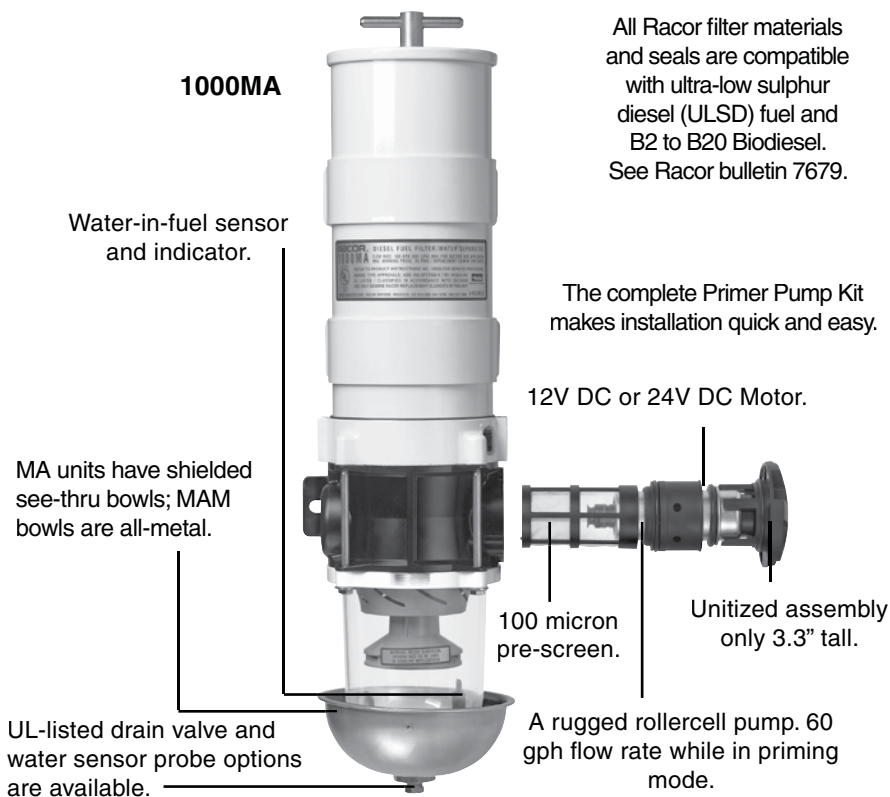

And more...

Turbine Series Electric Primer Pump

The Turbine Series Electric Primer Pump Kits can be retrofitted to many of the Racor 900 or 1000 series fuel filters already in service. The Filter Pump is an innovative and proprietary system consisting of a pre-screen filter, a flow bypass circuit and a roller cell pump powered by a DC motor. When the switch is activated the fuel is drawn into the pre-screen and then pumped through the housing, refilling the unit with fuel. When not in use the Filter Pump system is bypassed and the Racor fuel filter/water separator functions normally.

The RKP1912, 12V DC Kit, contains a traditional brushed motor design. The RKP1924, 24V DC Kit, contains innovative brushless motor technology.

The use of this primer pump kit allows the operator to easily re-prime the Racor Filter/Separator directly from the fuel storage tank with no mess

Marine Turbine Series filter assemblies are designed to be installed on the vacuum side of the fuel transfer pump for best efficiency and protect precision engine components from dirt, rust, algae, asphaltines, varnishes, and especially water, which is prevalent in engine fuels. They remove contaminants from fuel using the following legendary three stage process:

Stage One: Separation

As fuel enters the filter assembly, it moves through the centrifuge and spins off large solids and water droplets which fall to the bottom of the collection bowl.

Stage Two: Coalescing

Small water droplets bead-up on the surface of the conical baffle and cartridge element. When heavy enough, they too fall to the bottom of the bowl.

Stage Three: Filtration

Proprietary Aquabloc II cartridge elements repel water and remove contaminants from fuel down to 2 micron (nominal). They are waterproof and effective longer than water absorbing elements.

1000 Series Overview

Applies to all models.



Specifications	1000MA	1000MAM	1003MA	731000MA	731000MAM
M					
Maximum Flow Rate:					
One Filter On-line	180 GPH (681 LPH)	180 GPH (681 LPH)	180 GPH (681 LPH)	N/A	N/A
Two Filters On-line	N/A	N/A	N/A	360 GPH (1363 LPH)	360 GPH (1363 LPH)
Application	Diesel	Gasoline or Diesel	Diesel	Diesel	Gasoline or Diesel
Port Size	7/8"-14 (SAE J1926 female threads)	7/8"-14 (SAE J1926 female threads)	1/2"-14 NPT (female threads)	3/4"-14 (SAE J476 male threads)	3/4"-14 (SAE J476 male threads)
Height	22.0 in. (55.9 cm)	21.5 in. (54.5 cm)	22.0 in. (55.9 cm)	22.0 in. (55.9 cm)	21.5 in. (54.5 cm)
Width	6.0 in. (15.2 cm)	6.0 in. (15.2 cm)	6.0 in. (15.2 cm)	16.5 in. (41.9 cm)	16.5 in. (41.9 cm)
Depth	7.0 in. (17.8 cm)	7.0 in. (17.8 cm)	7.0 in. (17.8 cm)	12.0 in. (30.5 cm)	12.0 in. (30.5 cm)
Weight	10 lb (4.5 kg)	11 lb (5.0 kg)	10 lb (4.5 kg)	26 lb (11.8 kg)	27 lb (12.2 kg)
Clean Pressure Drop	0.5 PSI (3.4 kPa)	0.5 PSI (3.4 kPa)	0.5 PSI (3.4 kPa)	1.7 PSI (11.7kPa)	1.7 PSI (11.7 kPa)
Maximum Pressure	25 PSI (1.0 bar)	25 PSI (1.0 bar)	25 PSI (1.0 bar)	25 PSI (1.0 bar)	25 PSI (1.0 bar)
Water Capacity	10.3 oz (305 ml)	10.3 oz (305 ml)	10.3 oz (305 ml)	20.6 oz (610 ml)	20.6 oz (610 ml)
Overhead Clearance	10.0 in. (25.4 cm)	10.0 in. (25.4 cm)	10.0 in. (25.4 cm)	10.0 in. (25.4 cm)	10.0 in. (25.4 cm)
Water Removal	99%	99%	99%	99%	99%
Efficiency	° to +250°F (-40° to +121°C)				
Ambient Fuel Temperature	-40				
Maximum Fuel Temperature	190oF (32oC)				

How to Order

(The example below illustrates how the part numbers are constructed).

1000MA	M	10
Basic Model Use model 1003MA for 22x1.5 mm metric thread	Add M for metal bowl.	Add: 2 (for 2 micron) 10 (for 10 micron) 30 (for 30 micron)

Replacement Element (seals included)		
2020SM-OR	2 micron	Final
2020TM-OR	10 micron	Secondary
2020PM-OR	30 micron	Primary ¹

¹ A secondary or final filter is required downstream.

All 2020 Series filters are 9.6" tall by 4.7" in diameter.

Not all configurations are available - contact Technical Support for more information.

Mounting Information

1000MA
Certifications

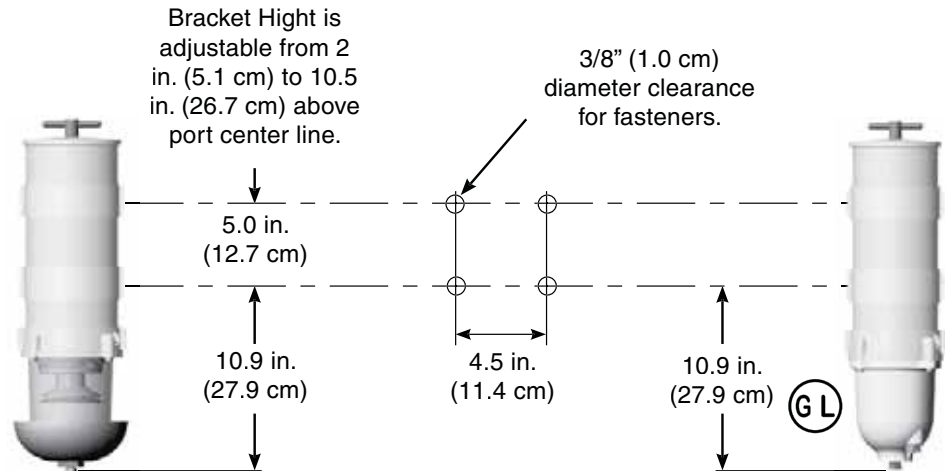

How to Order

(Test results are from controlled laboratory testing, field results may vary.)



500MA 500MAM

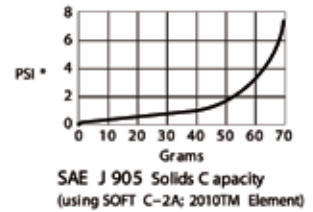
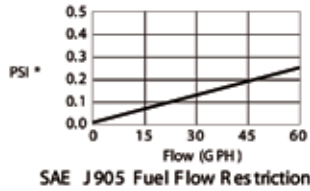

900MA 900MAM

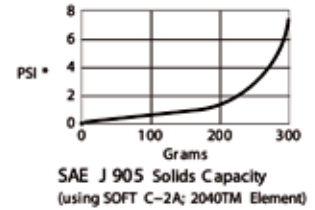
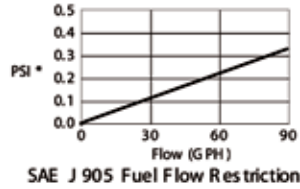

1000MA 1000MAM

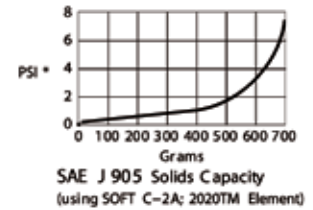
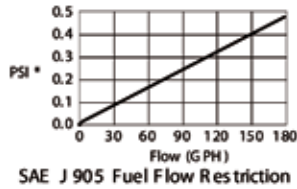

731000MA

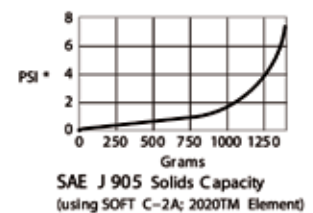
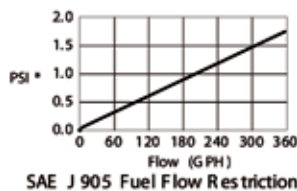

*PSI X 2.036 = inHg. / PSI X 6.895 = kPa

Installation Instructions

New filter installations must be filled with fuel and the fuel system must be adequately primed following the engine manufacturer's recommendations. Existing installation difficulties are usually associated with improper priming procedures or damage to the unit or fuel system. The result is either internal air suction or external fuel leakage. Diagnose with the following steps:

- 1. Check fuel tank level and verify fuel delivery valves are open.**
- 2. Verify T-handle, bowl fasteners and fuel fittings are tight and bowl drain is closed.**
- 3. If element is new, check potential restriction at fuel tank draw tube. An in-tank strainer may be plugged.**
- 4. Review other troubleshooting instructions to uncover other solutions.**

Correct external fuel leaks immediately! These conditions result in reduced engine performance such as: hard starting, stalling, reduced power and fire hazards.

Correct Application

It is very important that Turbine Series filter assemblies are not 'under specified' for the application. The maximum fuel flow rating of the filter assembly must not be exceeded; doing so will reduce efficiency and de-gas (pull air from) the fuel.

Filter Elements

Replacement elements are available in 2, 10 and 30 micron ratings (nominal). Filtration needs are based on application, fuel quality, maintenance schedules and operating climates. A simple rule to remember is... the finer the filtration, the more frequent the filter change interval.

Always carry extra replacement elements with your equipment as one tankful of excessively contaminated fuel can plug an element quickly. When clogged to maximum capacity, elements will have a brown to black color or tar like contaminants may be present - this is normal. An appearance of a multi-colored slime (which may have a foul odor) is an indication of microbiological contamination. This condition must be treated immediately. Racor offers a wide variety of gasoline and diesel additives to prevent and treat these problems; see 'Additives' section of this catalog. Severe conditions must be corrected by a repair facility.

Never operate a filter assembly without the element in place.

The element safety valve on the fuel return tube will not expose the outlet hole if the element is removed. Instead, punch the emergency tab on the top of the element and leave in place.

Warning! Puncturing the emergency tab will bypass all filtration and send unfiltered fuel to your engine. Service the element as soon as possible to avoid harmful contaminants flowing downstream to the engine.

Water Sensors

This feature alerts the operator of a high-water condition. The bowl must be drained of water at the earliest convenience.

A Racor water detection module is needed to work with the in-bowl sensor.

The unit should activate when the water reaches the sensor tips (and when they measure below 47,000 or 100,000 ohms of resistance, depending on the detection module used). If not, the tips may be fouled with a coating. Remove the sensor and clean the tips with a cloth. Run a jumper wire between the tips with the ignition ON to test the system. Difficulties usually lie in the wire connections, power source, or an independent ground.

Marine Turbine Series

All Marine Turbine Series filters are 100% tested to ensure a leak-proof, quality product.

Apply Parker Super O-lube (part number RK31605) or equivalent to all seals at major attachment points to maintain integrity, seal elasticity, to fill small voids and provide protection from degradation.

Perform the following checks with the engine OFF (and applicable valves closed). For replacement parts, refer to the appropriate 'Replacement Parts' section of this catalog.

Damaged, worn, or dirty seals will allow air ingestion. Inspect and replace all seals as needed. Lube all seals with Parker Super O-lube. Clean sealing surfaces of dirt or debris every time element is replaced.

Hand tighten T-handle; do not use tools!

If element is changed or assembly drained for any reason, repriming assembly (filling with fuel) may be necessary. Fill to just above top of element before replacing lid.

Do not overtighten carriage bolt as this may distort cylinder roundness.

Do not overtighten self-tapping screws; this may strip the threads. After disassembly, start screws by hand prior to using tools. Specification: 55 to 65 in. lbs.

The hollow aluminum check-ball floats up against the seal when the fuel is stopped thus preventing fuel bleed-back. If your unit loses prime, inspect upstream hose connections first, otherwise, disassemble the unit and inspect the seal and ball.

Drain water before it reaches this level.

Air bubbles or fuel leakage appearing from drain may indicate that drain is closed completely or that seal has been clogged with contaminants. Tighten drain and inspect: If self-venting drain will not work when opened, it may be clogged. Cycle drain (open-close) or attach a hose and briefly apply air (<2-3 PSI with T-handle and lid removed) to dislodge contaminants.

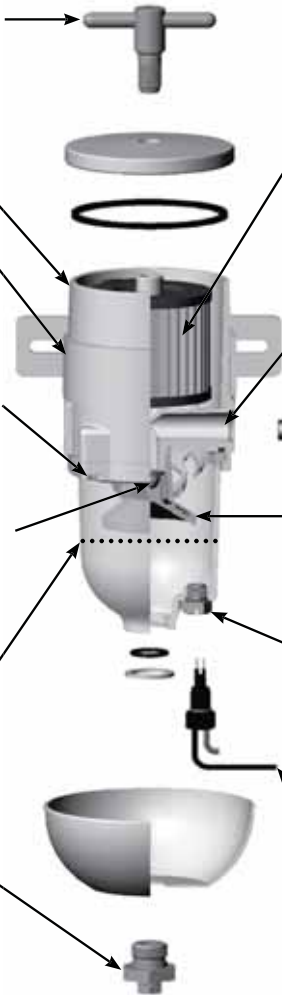

Element should be replaced every 10,000 miles every 500 hours, every other oil change, annually or at first indication of power loss, whichever occurs first. Construction and agricultural equipment should change element every 300 hours.

SAE O-ring ports should have a smooth angled seat for sealing. Do not scratch this surface. Check O-ring for damage. Replace if necessary.

Heater feed-thru O-ring must not be damaged or swollen. Tighten snugly. Specification: 15 to 20 in. lbs.

Air bubbles appearing from turbine are an indication of an upstream leak between Racor inlet and fuel tank pick-up tube.

A water sensor plug is standard equipment on new assemblies. Water sensor kits are available as accessories; see the 'Accessories' section of this catalog. Tighten plug or water sensor snugly. Specification: 15 to 20 in. lbs.

Water sensors activate when water contacts the sensor tips. Air bubbles or fuel leakage appearing from sensor area may indicate that it is loose or O-ring is damaged. Tighten or disassemble and inspect. Specification: 15 to 20 in. lbs.

LG Series

Eliminate Fuel Vent Line Overflow During Refueling!

Next time you fill up, watch your fuel vent line. A typical refueling will send up to a half a gallon of fuel spilling overboard. Fuel spillage is not only expensive, it's absolutely deadly to fragile lakes, rivers and waterways. Also, USCG and other regulations prohibit the discharge of oils and violators could face civil and criminal penalties.

Installed in the fuel tank vent line, the Racor Fuel/Air Separator efficiently separates air from fuel forced into the line. Air is vented, and fuel is returned to the tank. The Fuel/Air Separator captures fuel normally discharged due to agitation and thermal expansion (up to 2.4 PSI). It also eliminates damage to expensive striping and labels and protects finishes from fuel stains.

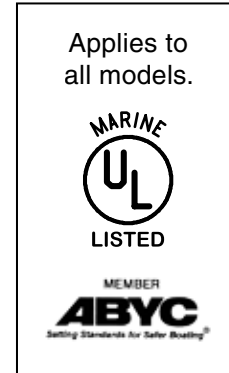

Specifications	LG50	LG100
Application: Gasoline Diesel	Yes No	Yes Yes
Maximum Air Flow Rate¹	12 CFPM (5.6 LPS)	17 CFPM (8.0 LPS)
Hose Barb Size	5/8"	5/8"
Thermal Expansion	2.4 PSI (0.17 bar)	2.4 PSI (0.17 bar)
Height	6.0 in. (15.2 cm)	9.75 in. (24.8 cm)
Diameter	1.75 in. (4.5 cm)	4.0 in. (10.2 cm)
Weight (dry)	1.2 lb (0.5 kg)	1.6 lb (0.7 kg)
Case Quantity	12	9
Operating Temperature	-40° to +255°F (-40° to +121°C)	

Notes: ¹Flow rates are in cubic feet per minute (CFPM) and liters per second (LPS).