

# Marine Fuel Filtration

## Marine 800 Series



Specifications	812MA	75812MA	79812MA
<b>Maximum Flow Rate</b> (one unit online) (two units online) (three units online)	720 GPH (2725 LPH) N/A N/A	720 GPH (2725 LPH) 1440 GPH (5450 LPH) N/A	720 GPH (2725 LPH) 1440 GPH (5450 LPH) 2160 GPH (8175 LPH)
<b>Port Size</b>	1" NPT	1" NPT	1" NPT
<b>Replacement Elements</b>	RK22610	RK22610 <sup>1</sup>	RK22610 <sup>1</sup>
<b>Micron Rating nominal):</b> (upper element) (lower element)	40 Coalescer	40 Coalescer	40 Coalescer
<b>Height</b>	33.2 in. (84.3 cm)	33.2 in. (84.3 cm)	33.2 in. (84.3 cm)
<b>Width</b>	6.6 in. (16.8 cm)	21.8 in. (55.4 cm)	33.3 in. (84.6 cm)
<b>Depth</b>	8.8 in. (22.4 cm)	16.0 in. (40.6 cm)	16.0 in. (40.6 cm)
<b>Weight (dry)</b>	36.0 lb (16.3 kg)	89.0 lb (40.4 kg)	133.0 lb (60.4 kg)
<b>Min. Service Clearance:</b> (above assembly) (below assembly)	12.0 in. (30.5 cm) 4.0 in. (10.2 cm)	12.0 in. (30.5 cm) 4.0 in. (10.2 cm)	12.0 in. (30.5 cm) 4.0 in. (10.2 cm)
<b>Max. Working Pressure</b>	30 PSI (2.07 bar)	30 PSI (2.07 bar)	30 PSI (2.07 bar)
<b>Differential Pressure</b>	3.2 PSI (0.22 bar)	3.3 PSI (0.23 bar)	6.0 PSI (0.41 bar)
<b>H<sub>2</sub>O Removal Efficiency</b>	99%	99%	99%
<b>Operating Temperature</b>	-10° to +180°F (-23° to +80°C)		

<sup>1</sup> 75812MA assemblies require two **RK22610** element kits and the **79812MA** requires three.

# Marine Fuel Filtration

## Marine 800 Series

2

### Installation Instructions

#### Before installing the filter assembly:

- Obtain good ventilation and lighting.
- Maintain a safe working environment.
- The engine must be off for installation.
- DO NOT smoke or allow open flames near the installation.

#### When positioning the filter assembly:

- Filter assemblies should be installed on vacuum side of fuel transfer pump for optimum water separating efficiency. See Installation Diagram.
- Keep fuel line restrictions to a minimum. Locate filter assembly between horizontal planes of bottom of fuel tank and inlet of fuel pump, if possible. If filter assembly is installed in an application where fuel tank is higher than filter, a shut-off valve must be installed

between tank and filter assembly INLET. This will be used when servicing replacement elements.

#### Installing the filter assembly:

- Install the unit in a location which provides accessibility and protection from heat, flames, or accidental impacts. Always adhere to applicable local piping regulations or codes. Use the maximum line size possible and avoid reducers and elbows in order to keep restriction values as low as possible.
- Apply thread sealant (do not use thread tapes) to inlet and outlet fittings prior to installing onto filter assembly.
- When routing hose, avoid surfaces that move, have sharp edges, or get hot (such as exhaust piping).

### Mounting Information

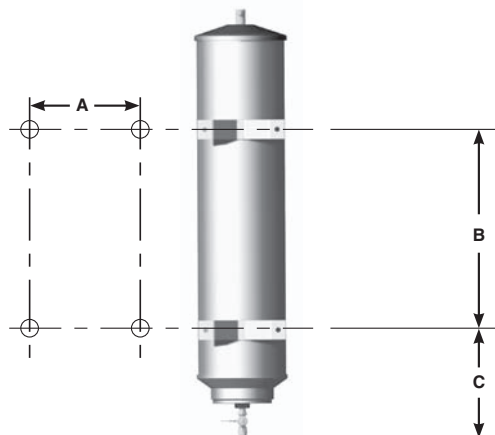

A:

812MA: 5.5 in. (13.8 cm)  
75812MA: 20.3 in. (51.4 cm)  
79812MA: 31.8 in. (80.8 cm)

B:

812MA: 15.5 in. (39.2 cm)  
75812MA: 15.5 in. (39.2 cm)  
79812MA: 16.0 in. (40.6 cm)

C:

812MA: 8.3 in. (21.0 cm)  
75812MA: 8.6 in. (21.8 cm)  
79812MA: 8.1 in. (20.6 cm)



# Marine Fuel Filtration

## Marine 800 Series

### Priming Instructions

1. Close inlet fuel valve, if applicable.
2. Remove T-handle(s) and lid(s) from top of filter assembly.
3. Fill filter assembly with clean fuel.
4. Lubricate lid gasket(s) and T-handle O-ring(s) with clean fuel or motor oil.
5. Replace lid(s) and T-handle(s) and tighten snugly by hand only - do not use tools.
6. Open inlet fuel valve, if applicable.
7. Start engine and check for leaks. Correct as necessary with engine off.

### Draining Water

Drain water and contaminants by opening the self-venting drain. If more than 1.4 oz (40 ml) of fluid is drained, follow priming instructions above. Otherwise, start engine and allow air to purge from system prior to operating equipment at normal loads.

### Element Replacement

Frequency of element replacement is determined by the contamination level in fuel. Recommended service intervals are as follows: every 10,000 miles, 500 hours, every other oil change, annually, or at the first indication of power loss, whichever comes first.

Foul smelling fuel is an indication of microbiological contamination. A change of fuel source and Racor fuel additives are recommended. Always carry extra replacement elements as one tankful of excessively dirty fuel can plug a filter quickly.

1. Close inlet fuel valve, if applicable, and completely drain filter assembly.
2. Remove T-handle(s), lid(s) and lid gasket(s).

3. Remove elements from inside housing(s) and dispose properly.
4. Lubricate new element(s) seals with clean fuel or motor oil and insert coalescer element(s) first, then the 40 micron paper element(s).

Insert new elements SLOWLY with a slight twisting motion. Inserting them too quickly may dislodge element seals.

5. Install new lid gasket(s), supplied with new elements, into lid groove.
6. Follow priming instructions above.

### Recycling Filtering

Recycling or filtering fuel in storage tanks cleans the fuel while removing particulates and sediment accumulations. Fuel should be recycled numerous times, depending on the severity of contamination. Filter/recycling clock times can be reduced by selecting a larger capacity unit.

Severely contaminated fuel may require several cleaning cycles to clean the fuel properly. Cycle time (the amount of time it takes to clean an entire tank of fuel one time) can be reduced by installing a duplex (75812MA) or triplex (79812MA) recycling system. For example, the 812MA recycler filters up to 720 gallons per hour (GPH) or 12 gallons per minute. The cycle time for a 100 gallon tank of fuel would be about 8.3 minutes. Depending on the contamination level of the fuel, one cycle may be enough to clean the fuel properly. If the fuel requires additional cleaning (more cycles), cleaning the fuel can become time consuming, especially if your filtering tanks larger than 100 gallons. By installing a 75812MA (maximum flow rate is 1440 GPH), the same 100 gallons of fuel can be clean in a little over 4 minutes (one cycle); a 79812MA would cut the cycle time down to around 3 minutes. If time is the issue, installing a duplex or triplex recycling system is the answer.

**RACOR**

Technical Support:  
800.344.3286 ext. 7555  
racortech@parker.com

# Marine Fuel Filtration

## Marine 800 Series

2

### Installation Diagram for 812MA

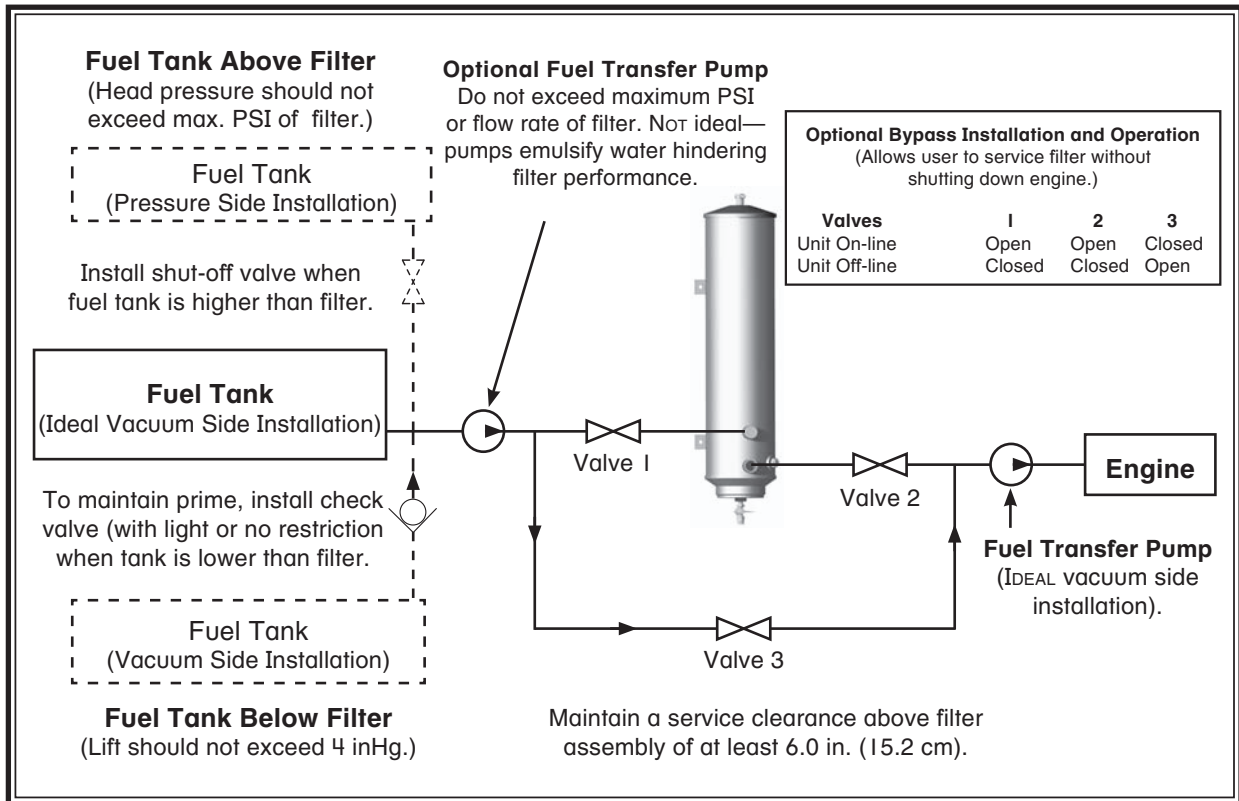

# Marine Fuel Filtration

## Marine 800 Series

### Installation Diagram for 75812MA and 79812MA

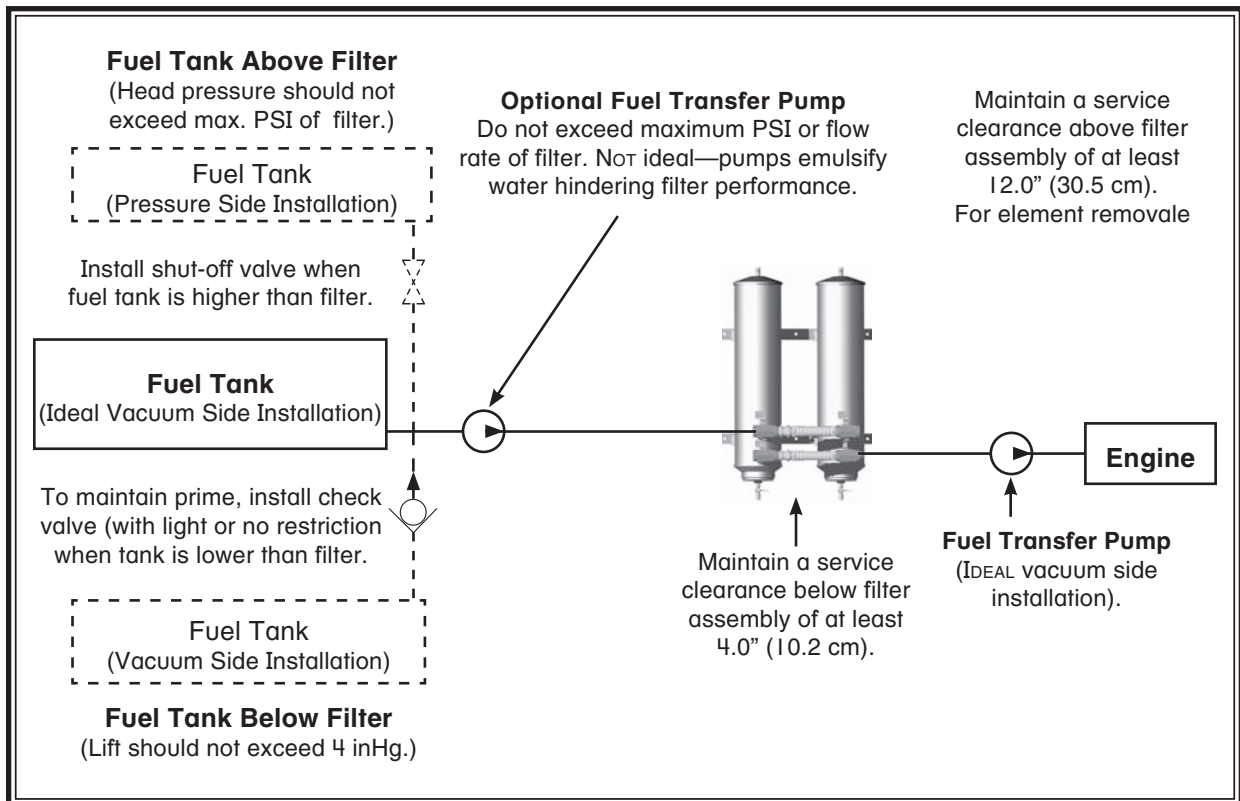

**RACOR**

Technical Support:  
800.344.3286 ext. 7555  
racortech@parker.com

316

**Parker**

# Marine Fuel Filtration

## Marine 800 Series

2

### Replacement Parts

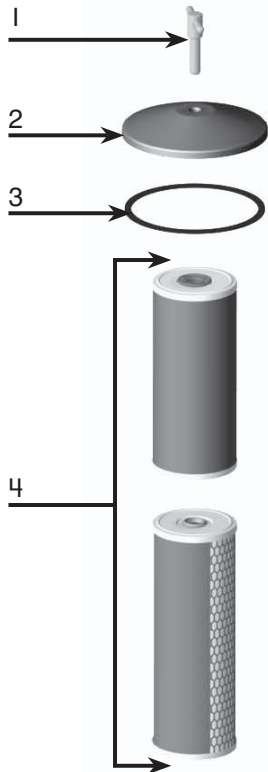

#### 812MA

	<u>Part Number</u>	<u>Description</u>
1.	<b>RK22688</b> <b>11350</b>	T-handle Kit T-handle O-ring
2.	<b>RK22682</b> <b>RK22609</b>	Lid Kit Lid Seal Kit
3.	<b>22609</b>	Lid Gasket
4.	<b>RK 22610</b>	812MA Element Kit (these kits include one 40 micron element, one coalescer element)
5.	<b>22675-B</b>	Metal Collection Cap
6.	<b>RK 19492</b>	Valve Kit

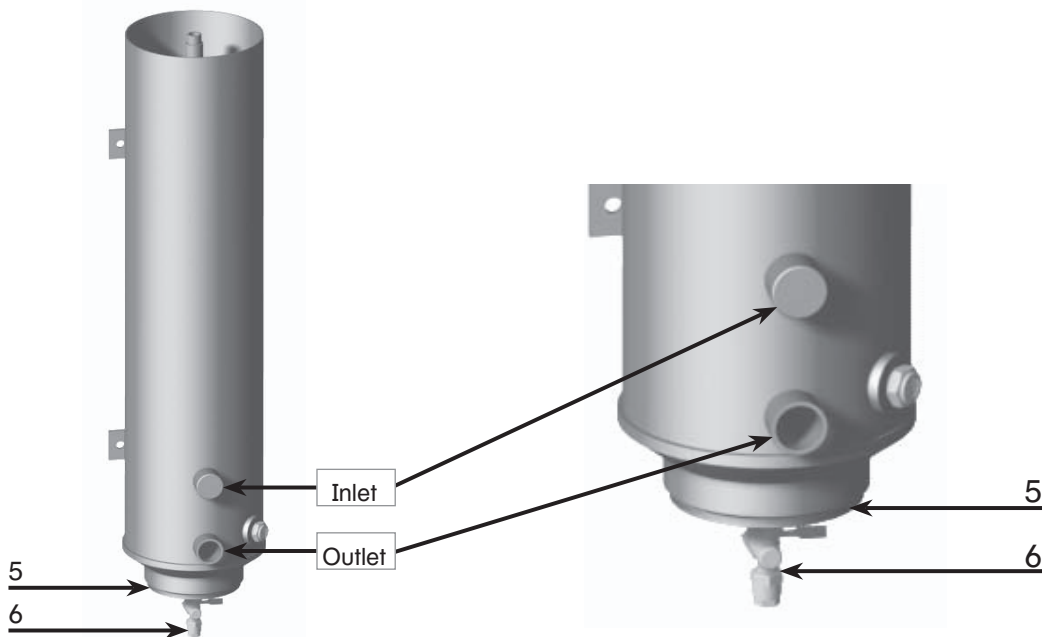

# Marine Fuel Filtration

## Marine 800 Series

### *Replacement Parts*

#### 75812MA and 79812MA

<u>Part Number</u>	<u>Description</u>
1. <b>812MA</b>	(See 812MA Replacement Part List)
2. N/A	Mounting Bracket (call Racor)
3. <b>RK22898</b>	Ball Valve Kit (includes one 1" NPTF ball valve and one 1" NPTF straight pipe adapter)
4. <b>RK22897</b>	Hose and Fitting Kit (includes one 1" NPTF straight pipe adapter, one hose assembly and one 1" NPTF pipe tee)

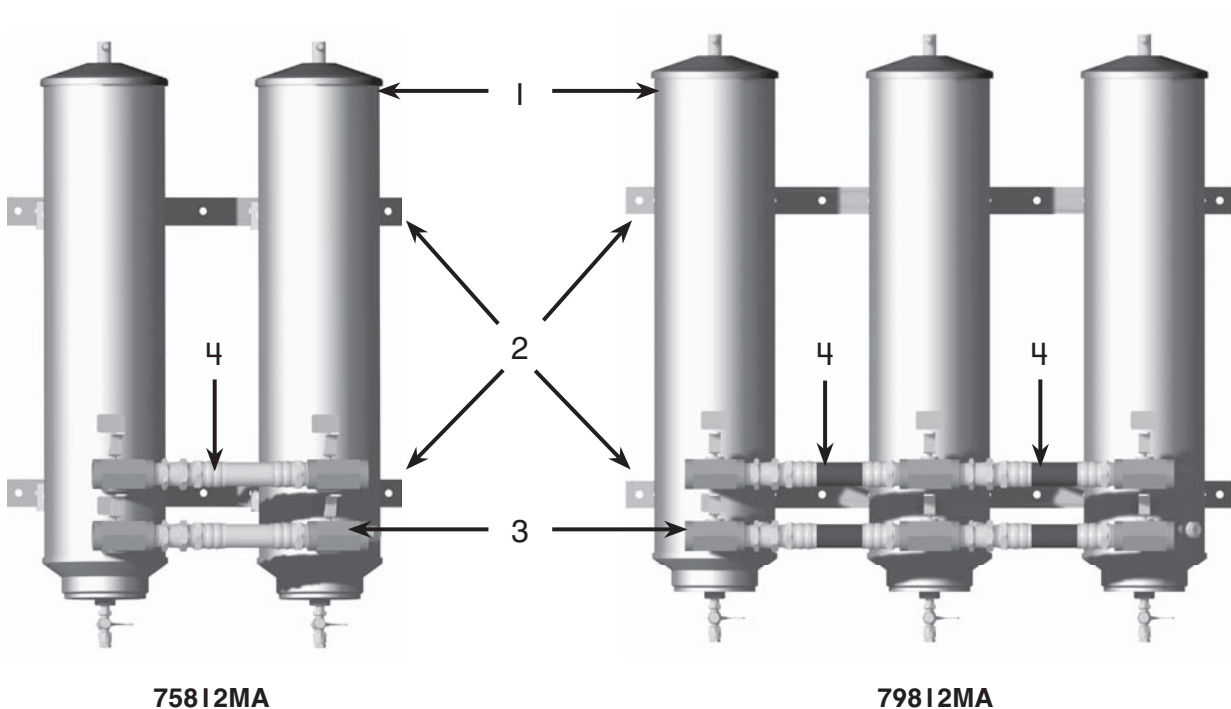

75812MA

79812MA

**RACOR**

Technical Support:  
800.344.3286 ext. 7555  
racortech@parker.com

318

**Parker**

# Marine Fuel Filtration

## Marine 800 Series

### 812MA Test Data

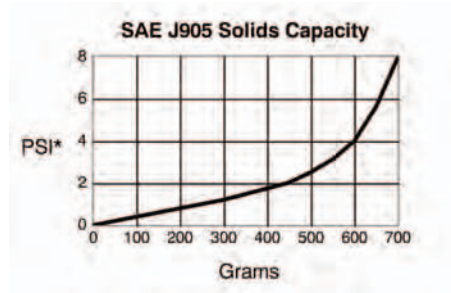
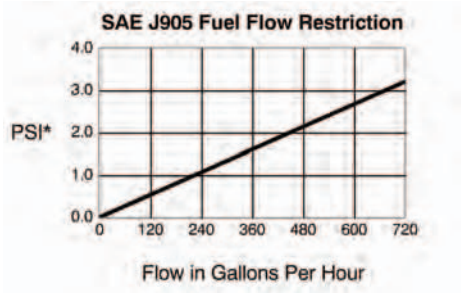

### 75812MA Test Data

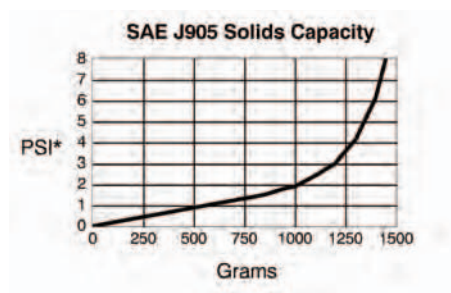
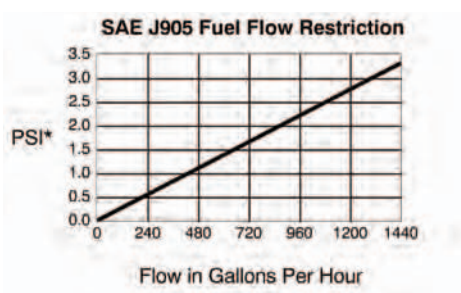

### 79812MA Test Data

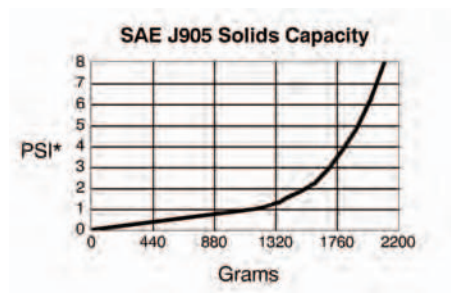
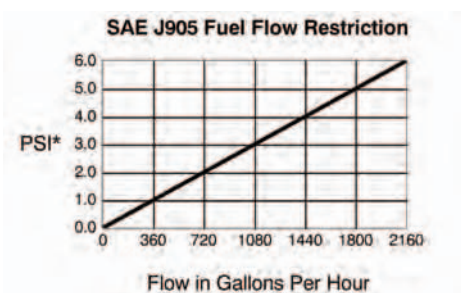

PSI X 2.036 = inHg (PSI X 6.895 = kPa)

Test results are from controlled laboratory testing. Field results may vary by application.





